



Douglas Lewis's 87 T-Type

I got hooked on Buicks about 6 years ago when I was looking for a G body. My friend, Juan Rios, said I should buy a Turbo Regal instead of a Monte Carlo. Man, am I ever glad that I listened to him. When I got my 87 T-type, it was stock and relatively slow, pulling a 14.0 second quarter mile. Over the years some small things were done like upgrading the chip, and Juan did some head-porting.

Then I met Tom Wilson (March '04 Fast Times cover feature), who helped a lot through the years. I bought his old turbo, chip, intercooler and traction bars and new 009 injectors. It was nice working on Tom's car with no rust only cob webs. Well, after I stripped his car, and added the goodies to my "T", it was off to the fall dyno-tech session where the numbers went up to 365 horsepower and 455 ft. lbs of torque!

Everyone was like "What did you do?" Well, besides the stuff I got from Tommy, I still have no idea what has been done to the motor. Whatever it is, it must be good! Next it was off to Victory Day where I ran my first 11.95! To say the least, I was HAPPY. I got a little scared when I saw glitter in my oil when I changed it, so now I stay off the dragstrip.

The only thing that I'm having done is that Bruce at B&M transmission is building one for me. It has been a fun ride; I have met lots of new people – especially Buick club members - whom are really nice. But I would really like thank Juan and Tom for all the help.

Thanks, guys! grinning like an idiot at Salem, Morocco or Byron, you now know why.

Chris says "Be our hero and participate in the judging at the GS Nationals". The qualification for helping out is your enthusiasm for Buicks. The cars are judged by how they are presented and not how "correct" they are. We will be looking forward to seeing you all there and please sign up at the CCGSCA tent for the judging. The car show as always will be Friday morning and for those who want some training Chris will be offering this as well.

Opinions expressed in this publication are not necessarily those of the GS Club of America, the Chicagoland Chapter of the GSCA, or any of the officers of these automotive enthusiast clubs.

Chapter Volunteers

Director	Loyd Bonecutter	708-485-8477 loydb@chicagolandbuick.org
Co-Director / Gran Sport	Steve Russo	815-795-4737 STEVEGS1@aol.com
Co-Director / Turbo Regal	Mark Holda	708-442-5580 M.Holda@comcast.net
Activities	Paul Brelie	708-452-8225 ELATED3@aol.com
Race Chairman	Brian Campbell	815-895-1796 gnracing@buickturbo.com
Treasurers	Marilyn Bachar	847-299-7244 waynebachar@msn.com
Secretary	Barb Holda	708-442-5580 metaz56@comcast.net
Membership	Shari Bonecutter	708-485-8477 sharib@chicagolandbuick.org
Graphic Artist	Paul Vilser	847-991-5556 pvilser@fortdearborn.com
Publisher	Paul Brelie	708-452-8225 ELATED3@aol.com
Advertising	Beth Andrews	847-845-7342 draena710@sbcglobal.net
4 th of July Show	Frank Jackowiak	630-655-0598 frank@itpphoto.com
Midwest Challenge	Bernie Rekus	660-668-4480 rekus@earthlink.net
Cruise Chairman	Chris Gatch	773-776-4794 cgatch@sbcglobal.net
Volunteers	Bob Nunes	847-455-7796
	Rich George	630-551-3120
	Bob Ward	847-854-3941
	Brian Campbell	815-895-1796
	Jason Stasiak	815-442-3263

Membership Policy & Dues

The Chicagoland Chapter of the Buick GSCA is open to all Buick enthusiasts and owners of Buick powered cars. Membership is \$20 per year, and includes a quarterly newsletter and much more. Apply online at the chapter web site or send dues with check made out to **CCGSCA** with membership form to:

Shari Bonecutter – Membership Chairman
Chicagoland Chapter GSCA
4010 Raymond Avenue
Brookfield, IL 60513-1846

Chapter Web Page

<http://www.chicagolandbuick.org>

Webkeeper - Loyd Bonecutter 708-485-8477

Please check the chapter web site for the latest information.

Member's Change of Address

Chicagoland members who move are requested to notify our membership chairman before the next newsletter mailing. We do not want you to miss a single edition of your newsletter. Please notify us of e-mail address changes as soon as you change providers.

Membership Renewal

Please check the label on your newsletter. If your membership was up in January, this will be your last newsletter. Obtain an application from the website or past issue, and mail to 4010 Raymond Avenue, Brookfield, IL 60513, along with a check for \$20 made out to "CCGSCA." Please don't let your membership lapse!

Volunteers for the Chapter

Note the various functions needed to operate this Chapter. Contact Bob Nunes if you are interested in helping our Chapter continue our pursuit of excellent Buick Motorsport activities for our members. It is very important to have fresh ideas introduced into the operation of the Club.

Upcoming Events

- Mar 13 March Meeting at ANS in Melrose Park
- Apr 24 Samatha Rix Memorial Race
- Apr 3 BOPC Swap Meet at Bridgeview Sports Dome
- Apr 9 Spring Dyno Session – ATR Joliet
- Apr 16 Carl's track rental at US 41 (must sign up)
- Apr 23-24 Spring Jefferson Swap Meet
- May 1 Buick Race Day in Norwalk, OH
- May 7 ? BCA Dust-off at Knautz (will post date)
- May 17-21 GSCA Nationals in Bowling Green, KY
- Jun 4 CCGSCA Picnic at Bruce and Shirl's
- Jun 19 Proposed date of second race in series at Byron
- Jun 26 BCA Woody Car Show (may change)
- July 4 Woodridge Police and CCGSCA Car Show

Director's Garage Loyd Bonecutter

Today according to the countdown clock on the web site the GS Nationals is 86 days away. That is great news as the 25th anniversary of the event will be a special one for sure. There is even a web site for the GS Nationals now and the GSCA Board has regular updates on the plans. I'm excited about the Friday night racing program planned, there was talk about skipping it for other events. The racing is definitely on again. If you have a choice of what to bring to the Nationals, please bring the GS. It would be great to see them in force this year. Shari and I will be breaking a long-standing tradition by taking her GS down for the second year in a row. This year the GS Nationals' official tee shirt will of course feature a GS. Of interest will be which year and color will be featured.

In the meantime there are a number of motorsport activities planned for our members. I think you will find this to be one the best year yet for the selection of Buick Motorsport activities, and hope you take advantage of many of them. Our racing committee will have an article in this issue of the newsletter and have put a lot of planning into the 2005 series. For those of you who like to occasionally exercise your

Buick this will present some great opportunities. Additionally for those a little more serious there is Buick Race day at Norwalk, the GS Nationals, BOP days at Union Grove and Cordova, the BPG Nationals plus many other Buick racing events as your willingness to travel increases.

As far as car shows Frank Jackowiak again has asked for CCGSCA assistance for the 4th of July show, now in the 12th year. That show plus our participation in the BCA All-Buick car shows gives us an area All-Buick show per month for late spring, summer and fall. All of these shows offer an opportunity to get together with Buick owners to share experiences, or show off your latest upgrade to your car.

The BOPC swap meet has been moved from the DuPage County Fair Grounds to the Dome off 294 in Bridgeview. Additionally it is on a different date. Please let everyone you know that plans to go about the changes. Hate to see folks travel a distance to find the event date has changed or even moved to a different location.

It is going to be a great year. Hope to see you with you Buick at a few events.

We have a new Classified contact. The owner of Da Wagon - Beth Andrews is in charge of classifieds.

Cruise News -Chris Gatch

Hello everyone! Ahhh! Spring is in the air! Well not really but that is my wishful thinking as I am writing this. But really spring will be here before you know it and it will be time to bring out our cars from their winters naps. Let's get ready for a great year!

World of Wheels was our first event of the year and it was a blast! This was the first time that a few brave souls would bring their cars out a little earlier then planned for all of the Chicagoland area to see. After a rather smooth move in process on Thursday and a hectic day of cleaning on Friday morning, the show opened for the entire public. Besides the beautiful cars, we also set up a television to show old tapes from our past events & past GS National events. This combination drew many curious onlookers to see what our cars can do. Many club members graciously answered the crowd's questions and curiosities they had. Once again I would like to personally thank everyone that showed up over the entire weekend and helped watch the cars while the car owners were away.

This year's display consisted of ten cars that awed and amazed the crowded halls of McCormick Place. All of the ten cars in the display took home plaques for their respective classes. The owners, classes and awards are as follows:

Steve Pitts	Pro-Street	Outstanding
Steve Pitts	Bracket Racer	Outstanding
Bob Kostuk	Altered Restored	Outstanding
Brad Crowe	Conservative Hardtop	Class Award
Cathy Johnson	Restored	Class Award
Bill Grupp	Conservative Hardtop	Class Award
Chris & Anna Gatch	Conservative Hardtop	Outstanding
Don Hens	Bracket Racer	Outstanding
Dave Falstad	Pro-Street	Outstanding
John Spina	Hand Built Sport	Outstanding

Thanks to all who braved the elements to come on out with their cars and also to those who came out and supported the club! We not only cleaned up with our cars but also got a participation plaque for participating in the Windy City Club Challenge!

As the start of the summer cruise/show schedule is right around the corner I would like to tell you about just a few of the shows that we are going to try and attend as a club this spring. To start the year, even though it's not a show or cruise, is the 14th annual B.O.P.C. at the Bridgeview Sports Dome. This is a new location for this event so please don't forget. This swap will be held on Sunday April 3rd. This is always a good place to go and get all those little things to get your car ready for spring.

Our first show is hopefully going to be the Spring Dust-Off at Knauz Motors in Lake Bluff on Saturday May 7th but as of right now this show is still in the works so please check the web site for more information. This event is hosted by the Chicagoland BCA, who always invites us to these premiere events. Even though this event is still in question the Woody, Loren and Marquardt shows are a definite so just check the web for further info about these shows.

Up next will be the Nat's in Bowling Green from the 17th -21st. This will be the 25th anniversary for this event and we expect the show to be bigger and better then ever so if you are there with your car why don't you enter your beauty! After we return from the Nat's we will have the complete Summer Cruise/Car Show Calendar together so if you have any suggestions please let me know. The next newsletter is due out June 1st. I am always looking for new car show and cruise spots for the club to attend so if you have any please let me know.

As usual Gorilla Days will be held on Monday July 4th and will be totally free as usual. This will be the 12th annual show so come on out and support this great event. This is probably the biggest collection of Buick's that you will see at a show in Illinois. The

show usually is from noon to 3pm with the gates opening at 10:00am. Once again please check the website for further details.

There are some key dates that I would like to mention for this year. Of course I have already mentioned the Nat's but the huge Buick shows don't end there. August will be a big month for these shows also. August 10th -13th will be the BPG Nationals in Salem, Ohio and they are planning their 2nd show, which will be on the 12th, and the following weekend will be the BCA's Midwest Regional event, which will be in Lincolnshire. The show on Saturday will be one of the biggest all Buick events in the area. So as you can see besides the many local shows and cruises as well as the bigger events planned there will be plenty for us to do this summer!

Here is the part where I would like to ask everyone once again for any information on cruise locations or car shows that you know about and would like us to attend as a group this year. Besides the usual Rally cruises there will also be some new spots that I am going to have on the calendar for our cruise events this year. If anyone knows of any events in their area that they would like us to add to the schedule please let me know. The earlier the better because it's really hard to get the word out and organize something a week or two before an event is going to happen. So remember any information is helpful and the earlier you can get it to me the better.

I would like to wish everyone a prosperous and safe upcoming year. The season is almost here so get those cars running, shine them up and prepare to bring them out this year for what promises to be a great one! Hope to see everyone "cruzin" this year and remember to *Keep Going Fast With Class!*

Chi-Town Kruze
June 5th
Soldier Field, Chicago
8 AM - 9 AM Registration
10 AM—Noon Kruze
11AM– 3 PM Car Show

The first Chi-town Kruze is on for June 5th, 2005. Owners of up to 2,000 classic cars are expected to take part in this cruise and car show—the first even of its kind in the City of Chicago. The participating cars will assemble in the Soldier Field South Lot and then follow a scenic route North through Chicago, looping back to Soldier Field where they'll gather for a classic car show. The show will include merchandise and food vendors, sponsor booths and entertainment for the whole family. Don't miss it!! More info at www.chitownkruze.com

TECHNICAL INFORMATION

Grand National – T-Type Analog Dash Cluster Tach/Boost Gauge -- GM Part Number 25077018

This article is written to explain some of the "genetic" defects associated with the bar-graph display in the lower right corner of the standard dash on the 1984-1987 turbo Regal. Specifically, it explains the persistent calibration problem where the bars light all the way up to 6000 RPM, displaying erroneous readings even when the car is idling. Other symptoms include inaccurate RPM readings and inaccurate BOOST readings along with missing or burned out segments.

The Tach/Boost module consists of three PC boards mounted into an assembly, and electrically connected by ribbon jumper cables. The upper PC board has five custom 10-segment LED bar displays along with some LED driver logic chips. The middle PC board has the A/D conversion circuitry, custom resistor network DIP chips, and is the PC board that we will discuss here. The lower PC board consists mainly of the power supply, filter and regulation circuitry, an LED driver IC, and a number of "hot" components. The three PC boards are "clam-shelled" together to form the display module. There is a wiring harness measuring about 13 in. long with eight wires attached and terminated by an eight-cavity female Metripack® connector.

This is the middle PC board which has the custom resistor network chips. The chip that controls boost is the larger chip in the upper left corner with the green top. The chip that controls the tach is the smaller white top chip in the center right.

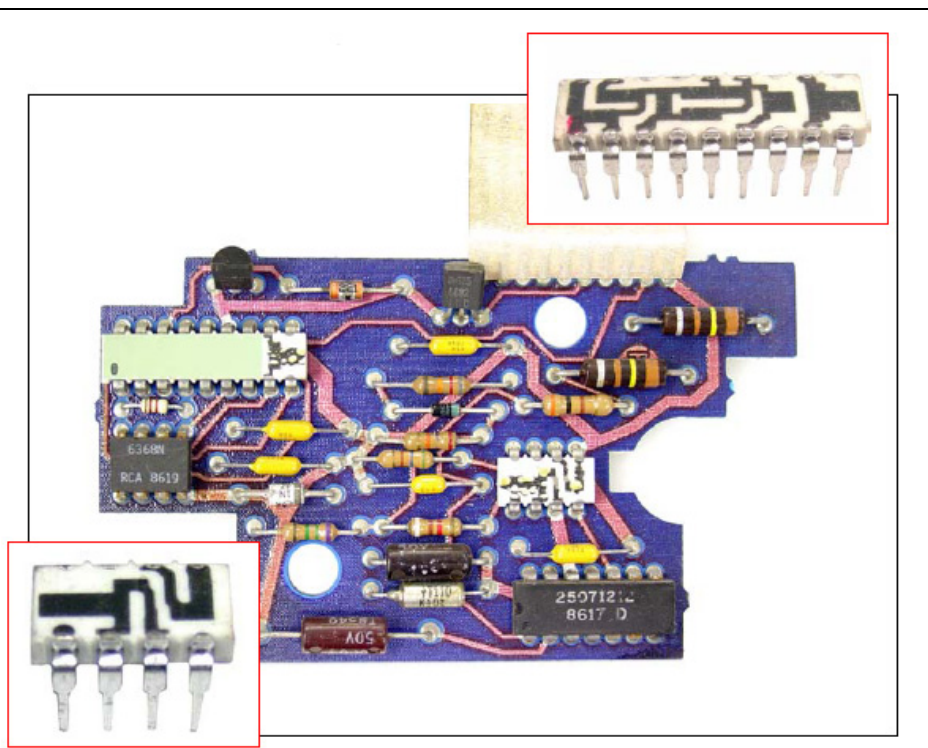

When this module was originally produced by GM for the turbo cars, it was assembled with these two resistor network chips prior to calibration. Once the module was ready to test, the two chips required calibration prior to final assembly. The calibration consisted of a fixture which the PC board was connected to, a "bed of nails" electrical connection system, and necessary test equipment. The technician would calibrate each network chip with a high power laser which would burn a very narrow path out of the calibration section of the network, providing necessary precise resistance in the circuit to enable the display to read RPM and boost properly and accurately. Let's fast forward fifteen-plus years later. We now see the effects of old technology and its characteristic problems related to aging components. The dash display that worked flawlessly when the car was new is not working so good now. The boost display shows 5 or 6 lbs. of boost at idle, which is not possible, and the tach display shows 3600 rpm when the engine is barely idling. This is a classical symptom of calibration drift. The drift, however is caused by something very hard to explain but easy to see. We have

observed physical deterioration to the un-protected layers of carbon that forms the resistance in the network chips.

The deterioration to these network chips can be seen here. Look closely at the two calibration network chips; you'll see blistering on the carbon traces in the un-protected areas of the chips.

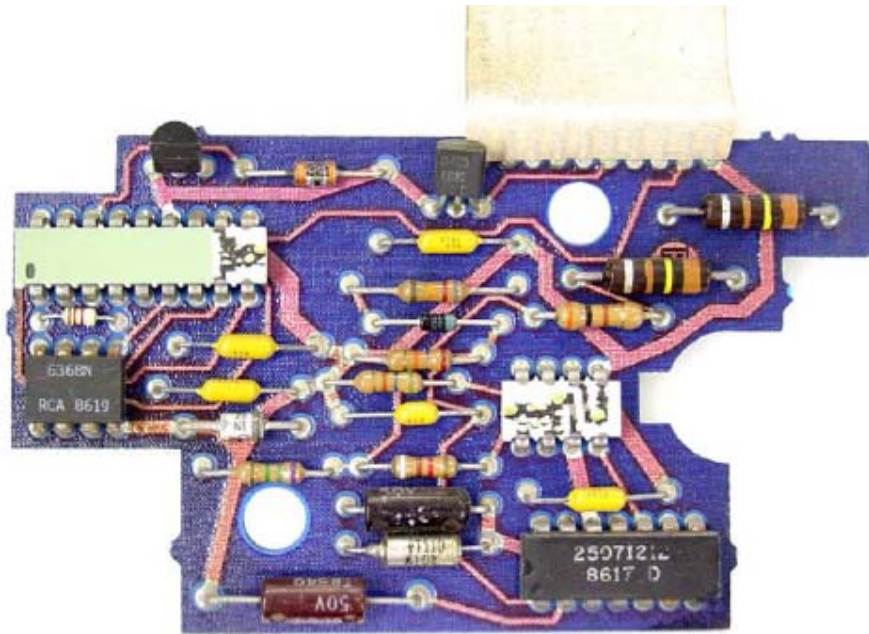

This happens because the carbon traces are exposed to air, moisture, and pollutants in the air. The carbon elements heat slightly during normal operation and when they cool, tend to collect slight amounts of moisture and salt deposits (particularly in climates near salt water). The effect causes the carbon to de-compose, leaving oxidized traces on the ceramic substrate of the network chip, and increasing the resistance to place the circuit completely out of calibration. We have also observed oxidation and conductive growth within the laser-etched area of the calibration slots.

Here is a closer look at the surface damage on the carbon traces of the network chip. Notice the bubbling areas where oxide has formed, changing the resistance of the carbon patch areas.

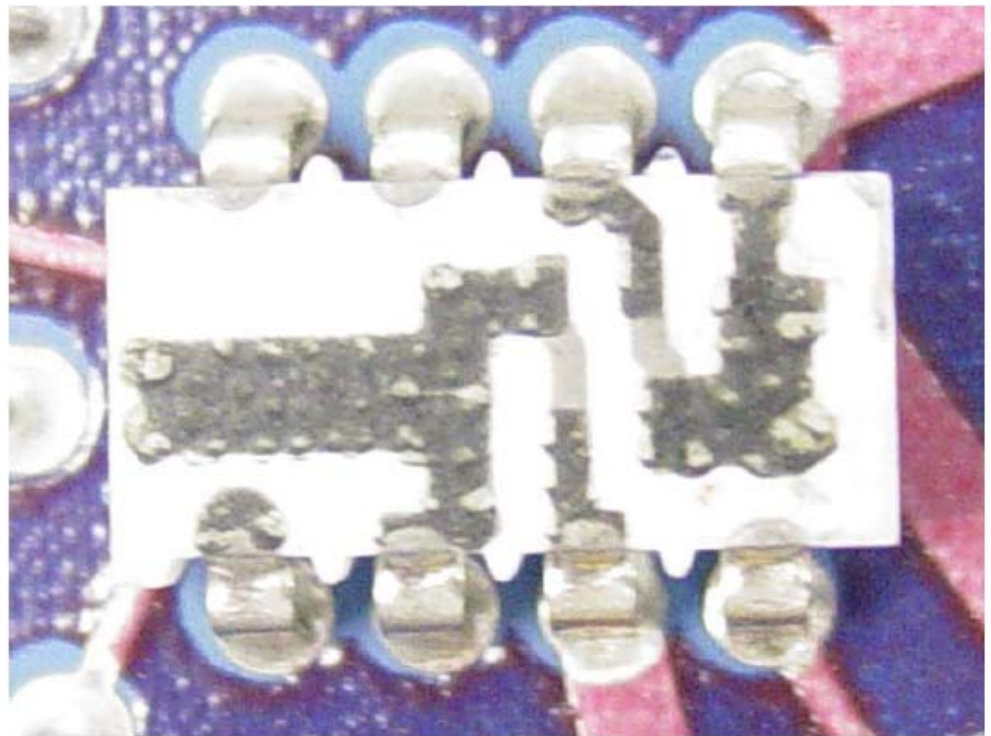

This problem seems to happen fairly consistently with the age of the vehicle. It now appears to be a

very common problem that eventually will happen to each and every turbo car fitted with this display. The tach section seems to be more prone to failure than the boost readout, and for an obvious reason. If you look at the larger boost control network chip, you will notice that most of the carbon traces on the ceramic substrate are coated with a green paint-like coating. Only the critical calibration resistance pad is exposed.

The tach control network chip (the smaller one) is fully exposed and prone to much more deterioration than the coated chip. Because these network chips weren't coated with any type of paint or sealant after calibration, they became prone to moisture damage. This is why the failure rate on these components is so high. And considering how it happens, it is likely that the failure trend will continue.

**It is quite probable that each and every
Boost/Tach module ever produced will require service!**

We do offer hope, however. We have tooled up for both of these resistor networks and can replace and calibrate the modules. The gauge module can be repaired and put back into proper function using new network chips and will restore your dash to the original fully functioning condition.

Here is a "before and after" view of these chips

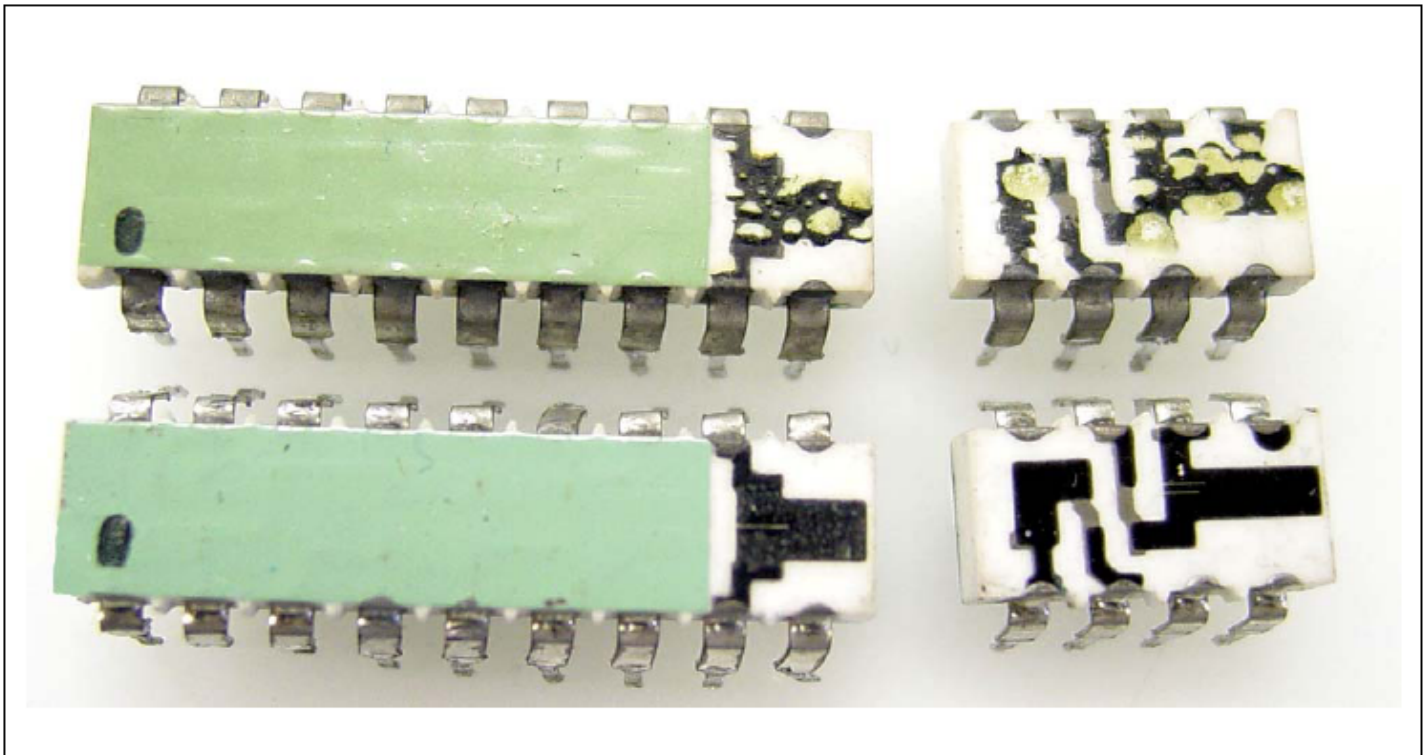

The repair and recalibration involves replacing both network chips, then recalibrating both the boost and tach sections of the module on the bench using a calibration standard. The calibration is performed using a diamond cutting tool instead of a laser, since the diamond tool doesn't exhibit extreme heat in the region of the resistor pad. The chips are then fully sealed with a coating after the calibration process.

The result is a fully functioning and calibrated Tach/Boost module that restores the originality of the turbo Buick. The additional surface coating will extend the integrity of the calibration procedure.

Copyright © 2004 Casper's Electronics Inc.

<p>PAUL'S TURBO-CHARGED CHILI</p> <p>4 LBS. 80% LEAN GROUND BEEF 1 TUBE CHORIZO MEXICAN SAUSAGE 2 PACKETS "HOT" CHILI SEASONING 2 YELLOW PEPPERS SWEET 2 RED PEPPERS SWEET 2 ONIONS 2 POBLANO HOT PEPPERS 5 JALAPENO PEPPERS 4 DRIED MEXICAN CHILI PODS 1 CAN HOT AND SPICY CHILI BEANS 2 CANS HORMEL HOT CHILI (NO BEANS) 3 CANS PETITE CUT ZESTY JALAPENOS PEPPER TOMATOES 1 JAR HOT PEPPER STUFFED OLIVES</p> <p>SALT AND PEPPER TO TASTE</p>	<p>Brown ground beef and chorizo sausage. Drain fat and save one cup of drippings. Return meat to low flame and add cup of drippings, seasoning packets, Hormel chili and zesty tomatoes. Simmer and stir 15 minutes.</p> <p>Chop up red peppers, yellow peppers and onions. Add to pot and stir.</p> <p>Put in separate pot the dried Mexican chili pods and boil until soft. While this is boiling, chop up poblano and jalapeno peppers.</p> <p>When chili pods are soft, take them out and cut off the stem and take out any seeds that may be inside. Slice the chili pods in small strips.</p> <p>Add can of beans, sliced chili pods and chopped poblano and jalapeno peppers to meat sauce. Stir thoroughly and let simmer for ½ hour.</p> <p>Add a dash of chili powder, chopped red peppers and sprinkles of chipotle hot pepper sauce and extra hot jalapeno sauce. Season with salt, pepper and season all until desired taste is met.</p> <p>Simmer for another ½ hour, stirring every 5 minutes.</p> <p>One may add additional hot peppers if desired beading of the forehead is not achieved. To get full enjoyment of the chili, refrigerate overnight so that the dish may ferment.</p> <p>This recipe will serve 15 to 20 bowls of chili. Ingredients may be cut in half to provide less amount.</p>
---	--

Scribblings – Shari Bonecutter

Hi, everyone! Well, we're starting on the downslide to spring! The days are getting a little longer, and the snow has melted. Hopefully it will be the end of the snow for this season, but I doubt it!

We've had a few activities to report on. Paul Brelie has done a most excellent job of this. I want to acknowledge the people that helped us. For the Christmas party, first of all I want to thank Terry Klemmer for helping us get the Moose Lodge. We really enjoyed this facility – lots of room to park, spread out, and the bartender was great! We also had several volunteers help us set things up – Frank Jackowiak, Paul and Linda Brelie, Jason and Stephanie Stasiak, Ken and Liz Stasiak, Wayne and Marilyn Bacher, Mary Ferrari, Chris and Anna Gatch. You guys did a great job – we really appreciated it! Brad Crowe donated a set of Lear Seigler seats, Barb Holda made a ton of Jell-O shots, and Beth and Dana Andrews donated the atomic cherries, chocolate liquor bottles, and the message pads. Midnite Mike and his "dancing girls" (a/k/a/ Martha and Connie) did their best to get the crowd to dance. We're getting better, guys. Paul Dubois and Steve Ekstrom did their final rendition of the 12 Days of Xmas with us. We'll be looking for someone to fill their shoes in 2005. And I want to thank all of you that attended – I think we had a record crowd this year – about 90 or so! Thanks for making us feel like someone appreciates our work.

January brings us to the meeting at John Spina's place, Casper's Electronics. John is so generous with us – letting us come back again to hold our meeting! We really appreciate the tables and chairs, too. John's a great guy! Mary again helped us schlep stuff back and forth, and Marilyn made some awesome sloppy joes. The usual gang supplied the soda and ice and coolers. We really appreciate the help!

Chris covered the World of Wheels, quite nicely. We had a great bunch of cars and people there, as usual. We even had a guy from Finland there, helping watch the cars during the award ceremony. I really appreciate you all taking the time to help with the display. That's what makes our club so cool – the willingness to help each other out.

February brought us to a new place to try out – Mr. Beef and Pizza in Mount Prospect. Wayne and Marilyn Bacher arranged for this, and I think they picked a great place for the meeting. We had enough space, plenty of pizza and soda, and a nice crowd showed up. If we go back here again, we'll probably use the raised area for our meeting, because we won't have to move from there. It was a nice fit, Wayne and Marilyn! Ken Stasiak explained some basics of Drag racing to the crowd, for the beginners. He did a great job – thanks, Ken!

Membership news

We have a couple of young'uns to welcome to the world. Sydney Noelle DuBois was born on October 15, 2004 to her parents Danielle and Paul. She

weighed 8 pounds 14 ounces and was 22 inches in length. Big sister Melanie is pleased.

Xander Rayce Dennis was born 01/22/05 to parents Sam Dennis and Brandi Woodward. He has a FULL head of hair, same as Sam's, and weighed 6 lbs 12 ounces, 20" long. He had a few complications at first, but is doing great now, as is Mom.

Big congrats go to Steve Russo and his bride, Tammy. They became man and wife February 12! We wish you a lifetime of happiness and Buicks!

Welcome back to the following members: John Jaffe, Grayslake, IL; Lloyd P. Andrew, Skokie, IL; Larry Baron, Brookfield, IL; Steve Chareas, Mount Prospect, IL; and Salam Fakhoury, Glendale Heights, IL.

Welcome to the following new members: Anish Elam, Romeoville, IL; Michael Koszyk, Merrillville, IN; Clifford Bryan, Schaumburg, IL; Michael Swert, Oak Brook, IL; Chad Emmel, Sycamore, IL; Michael Fadze, Chicago, IL and Garry Melvin, Streamwood, IL. Thanks for joining, you guys! I hope you all enjoy our club!

Upcoming events

The next 2 meetings are pretty cool. March is at Pete Barton's ANS in Melrose Park. We will be featuring AMP engine builders from Kentucky, and Paul Ferry's Hrpartsnstuff from Atwood, OH – something for both size of engines! And last but not least – the chili contest! Please bring a crock pot of what you think will win you a prize. The club will bring tables, zip cords, surge protectors, bowls, spoons, and soda. PLEASE BRING YOUR OWN CHAIRS!! You're on your own when it comes to a place to sit down.

April is the dyno session at ATR in Joliet. This is another fun time – I liken it to indoor racing. We will have a schedule set up on the website. The cost is \$50, and this will get you two pulls on the chassis dyno. Lunch and soda will be available, and we'll have a business meeting around noon. Here, too – BRING YOUR OWN CHAIRS! If you don't have web access, you can call Paul Brelie at 708-452-8225 or me at 708-485-8477 to schedule a time.

We have a bunch of races going on this year – there is a race committee that is working on the schedule and the points system. I do know that the Samantha Rix Race will be at Byron on Sunday, April 24th. We will also be attending the Buick-Olds-Pontiac races at both Great Lakes Dragaway and Cordova. Great

Lakes is scheduled for Sunday, June 5th, and Cordova is scheduled for Saturday, October 8th. It would be great if we could get a bunch of Buicks at each! Cordova is only about ½ hour further away than Byron, and in October it's a nice drive with the colors.

We'll be at the Nats, as usual! We will once again have a chapter tent, selling shirts, hats etc. We will be raffling off a mini-fridge down there. Don Hens graciously picked this up for us, and his son-in-law Dennis will be painting it for us. So come on by and buy a raffle ticket! Also, we have a bunch of rooms at the Courtyard. The rooms are going for \$79 a night, from Tuesday the 17th through Sunday the 22nd. You can call 270-783-8569 and ask for the Buick rate. We only have 30 rooms, and they won't be available after May 1. So call soon if you're interested!

We're doing something differently with the picnic this year. Bruce and Shirley Durband have held a great yard party for the past two years. This year, they're letting us combine our picnic with their party, on Saturday, June 4. They live just over the Wisconsin border, so it's a neat cruise to get there. They have a great yard, with lots of room for an informal Buick "show." We're actually holding this as a family event, as there is a great park right next door. There will probably be some kids games, as well. We are asking everyone to bring a large dish to pass, or bring some snacks or beverages. There will be some soda there, and some beer and wine coolers. The club will be supplying the burgers, hot dogs and some kind of sausage. This really is quite a fun party. If you've ever been a regular on the V-8 board you may meet some of the out-of-towners at this party – names that you've heard but never met. There will be a flier elsewhere in the newsletter, along with directions. Please take the time to let me know if you're coming, and how many. It would be a shame if we ran out of food!

One more event I want to mention is our Drive-Inn Outing. Yes, we're going to try this again! Last year, the two dates that we had picked out either got rained out or it was 30 degrees outside – too cold for us!! We're trying out the date of Saturday, June 11 this year. As before, we'll meet around 7:00 pm at the Steak and Shake west of the Drive In, in the west end of Menard's parking lot. Then we'll drive as a group to the Drive In, so we can all park together in the front row. Pray for warmer weather and decent movies this year – no snake movies! The theater is located in West Chicago on North Avenue, 1 ½ miles

east of Route 59. The Menards is west of Route 59. Please join us with your car – it should be fun!

One last thing – please check your label for your dues status. If it shows 1/1/05, this will be your last newsletter. You can keep it going by sending me a \$20 check made out to “CCGSCA” at the address listed in the front cover.

Hope to see you all this year – and maybe some new faces! The more participation we get from you the better. And let me know if anything changes in your life – babies, email addresses, moving, etc. Take care, all!

Please check your label for your dues status. If it shows 1/1/05, this will be your last newsletter.

Pauls recap of Past events

Here we are in 2005, I hope everyone had a festive holiday season, and that you're starting the New Year in good cheer. With the New Year, there were some events that took place that some of you may not have had the chance to participate in. I will attempt to cover some of the highlights of each.

First item of business would be our annual Christmas Party. In the past years, our Party has been held at the Brookfield VFW hall, and although the building was large enough to hold our event, the parking situation was a bit challenging. This year we tried something new. Through a mutual car fanatic, we were able to invade the River Grove Moose Lodge for a night. The first thing noticeable about the new location was the parking lot. No more parking a block away or fearing that you're parked in a tow zone. The adjacent parking lot to the Moose Lodge could easily hold 100 cars, if not more. The hall that was available to us was as equally oversized for our party, but it made for a very comfortable evening.

Here's just a quick recap of some of the highlights:

- Music Midnight Mike kept everyone festive and tapping their feet throughout the night, only taking a break for our annual “crowd participation” rendition of the 12 days of Christmas.
- Food Main entrée was catered this year, with some outstanding baked goods from a few members that included cookies, cakes and pies. Some additional goodies like jello shots and atomic cherries were also available.
- Raffle prizes Too many great gifts to even name, and one lucky person walked away with a 27” color TV!!! Lucky guy.
- Awards First, second and third place trophies were handed out for each of the three brackets we run. There seemed to be quite a few new faces accepting awards this time; racing in 2005 is going to be very competitive.
- Friendships Between the eating, singing, and raffle prizes there was plenty of time to sit down with old friends, as well as new ones, and catch up on some good stories.
- Growing pains As with any first time adventure, there were a few items that we as a club need to pay more attention to if we choose to hold our Christmas Party here again. Directions need to be more precise and non-alcoholic drinks need to be taken care of as part of the party package, but other than that everyone seemed to have a great time, and that's what its all about.

The club's first Tech Session of 2005 was held this January at Casper's Electronics. John Spina was on hand to discuss the problems that occur with the electronics in our older cars. Among some of the gremlins that he has encountered servicing our cars is the “wearing out” of some of the circuit boards that control the instrument clusters in the dash. Another serious problem seems to be our cars capacity to maintain a proper ground. Although these situations could eventually cause problems, John has a solution to fix these. John also spoke about a new product he is about to market. He has devised a crank sensor for the TR's that will almost install itself! It's exciting to see new products being developed for our cars, and John is best there is. All who attended also got a first look at Johns' twin turbo GN Spyder Project Car. To appreciate the craftsmanship that went into producing the car, you have to see it first hand. If you cannot make it out to some of the events where the Spyder will be showcased, at least go to Casper's website and take a look at the pictures he has posted. Our thanks to John and Casper's Electronics for hosting an informative and entertaining tech session.

The World of Wheels event held at Chicago's McCormick Place always brings out the best of the best. There was no exception to that rule for our club members who participated this year. I know having a car entered there is a lot of work,

and those who did take the time to display their cars and promote our club deserve a round of applause. I enjoy spending a day there hanging around with the club members and answering questions from curious onlookers. If you have never been to one of the shows I suggest it highly. I am sure the show will be mentioned in detail somewhere else in the newsletter, so read on for details of which cars were there and whom the winners were.

Until next time, show it, race it, fix it or break it, doesn't quite matter what you do, just do it! Paul Brelie

GS Nationals Car Show Judging Help

-Chris Gatch

The 25th annual GS Nationals car show is right around the corner and we are looking for club members to help judge once again for this year's show! The Chicagoland Chapter has coordinated the judging portion of this show for the past 5 years now and this year will be no exception. So if you plan on being at this year's event, why not help with the judging portion of the greatest Buick car show on earth! We are expecting a large turnout for this show since it will be the 25th anniversary so the more people that are willing to help the better! Where else can you see Buicks from across the county this up close and personal?

So you say that you have never judged before? Well, don't worry - you don't have to be an expert. It would help if you have a keen eye, a love for cars and the willingness to help out! If you have judged this show before then you know that it is not difficult. We hope that we can once again use your experience. If you have a car in the show, that is no problem either. You

are more than welcome to judge the show with the exception of your own class. This years judging is based on a points system. Everything will be written out for you on the judging form and is relatively simple to fill out. Once again all judges will be receiving a trinket for their time and help with the show. We will also have cold water available. What can be better than talking Buick with the other members on your three-person team? What better way to learn more about the best cars on earth than to judge them?

Our club's responsibility is to help make the judging at this event go smooth so if you can spare some time for judging please help out. Please help us show what makes the Chicago Chapter one of the greatest clubs in the GSCA family!

If you have any further questions about this event you can contact me at (773) 776-4794 or email me at CGATCH@PORTER-ATH.COM and I will get back to you with your answers as soon as possible. Hope to see you there!

Here are the classified for this issue. Sure hope you find something here

1987 GN hardtop for sale

105,xxx miles, 10k on engine, 5k on trans. Racetronix Full hot-wire fuel pump kit, Walboro 340 fuel pump, Jay Jackson 62mm Throttle body; 50lb injectors with 2 chips, DIY alcohol injection kit, Postons 3" downpipe, Accufab fuel pressure regulator, BGC 23 row stretch IC, Ramchargers dual electric fan setup, GTA 16" rims, Aluminum drums, fiberglass bumper fillers, scanmaster V2.1, 2-5/8" oil pressure and boost pressure gauges on the a-pillar, high volume oil pump. \$7,200 or best offer. Email Dsmyth8604@aol.com. The car is located in Carol Stream, West suburbs of Chicago.

72 Skylark 350 2Dr with 79K miles

GS spoiler. MINT Brown interior. Car was garage kept and has clean soft perfect interior. Dashboard looks brand new - perfect chrome bezels. A/C blows hard at solid 32F. NOT MODIFIED or HACKED in any way. BONE STOCK 350 2 barrel with clean underhood and clean underbody. Bumpers are great - chrome is beautiful.

The car is in the body shop right now being worked on. Plan to have it ready for sale in the spring. It is getting a COMPLETE paint job - probably GOLD. Asking price when the car is finished will be \$8k. If you are interested PICK THE COLOR you want.

The car is located now at J+D Autobody in Crystal Lake IL. 847-639-9890 ask for Mark

I have a complete floor pan that has been cut into two sections just behind the rear seat. I can provide pics if needed. There is a small wrinkle in the trans tunnel, otherwise all is straight. Let me know if you are interested. **Bryan - admin@hotairbuick.com**

Info of the month

Original Replacement Body Panels for General Motors cars from 1970's to 1990's go to **Replica Plastics:**

<http://www.replica-plastics.com/buick.html>

Racing 2005 – By Bryan Campbell

It's time to start thinking about the 2005 racing season with the CCGSCA. I can just imagine all of the fresh parts just waiting for someone to put them on or maybe they are already on and just waiting for the fresh air of spring. I know I just can't wait to get back out to the track. There still is nothing like the smell of burning rubber and fresh race gas. Have I got you going yet? This year we are going to try a little different spin on our club racing. We sat down and had a small committee talk about the direction we wanted the club racing to go. We decided that we wanted to try and offer the die-hards and veterans something to go after, but not exclude the newer members from trying the sport of racing, which was not an easy feat. This is what we, as a collection of racers, have come up with for the 2005 points chase.

Vehicles must be Buick powered, as in the past. Points will be the accumulated in the following manner.

2005 CCGSCA Racing Series Points Guidelines									
Bracket	ET		1 st round loss	2 nd round loss	3 rd round loss	4 th round loss	5 th round loss	Runner- Up	Winner
1	11.99 and Quicker	# cars	30					60	80
2	12.00 to 12.99	4 or less	30	40				60	80
3	13.00 and Slower	5 to 8	30	40	50			60	80
		9 to 16	30	40	50	60		70	90
		17 to 32	30	40	50	60	70	80	100
		33 to 64	30	40	50	60	70	80	100

Bonus Points	Points	
Participation	20	Given for participants that compete in all five events. The driver must sign in and attempt to make a pass. Event coordination will count towards the participation bonus.
Perfect reaction time (.000)	15	One bonus possible per event/per person, across all brackets in competition only. Not awarded during testing and tuning.
Top MPH	15	Bracket 1 only, one per event
Low E.T	15	Bracket 1 only, one per event

We have also, through participation of the committee members, allowed points for event coordinator. An event coordinator will receive first round losing points and participation points.

Now here is the fun part.....this will be a "best of series". As of right now we have 5 events scheduled for 2005. We will take your best score from 4 of the 5. If the series drops a race for whatever reason, it will turn into a best 3 out of 4. Remember all track rules apply, just like in the past. If the track disqualifies you for any reason, they will have the final word. "Bye" runs will be coordinated by the event chairperson or their delegate. This will be the first year for changing things around, and we may encounter issues so please bear with us. Current info regarding points and issues will be posted regularly on the Chicagoland website message board. I wish everyone a safe and fun points series chase. GOOD LUCK!

Confirmed 2005 schedule:

April 24 - Samantha Rix Memorial Race - Byron July 17 - Great Lakes Dragaway August 28 - Byron
--